

ALFA YTP 1000



Kaynak Robot
Welding Robot



Toz Boya
Powder Paint



Test Edilmiştir
Tested



2 Yıl Garanti
2 Years Warranty

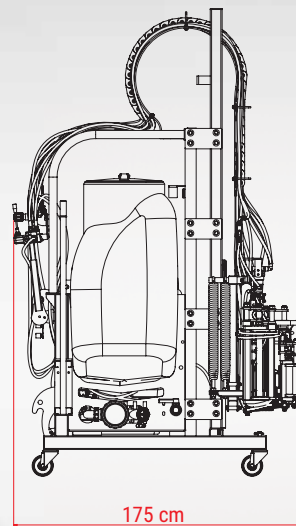
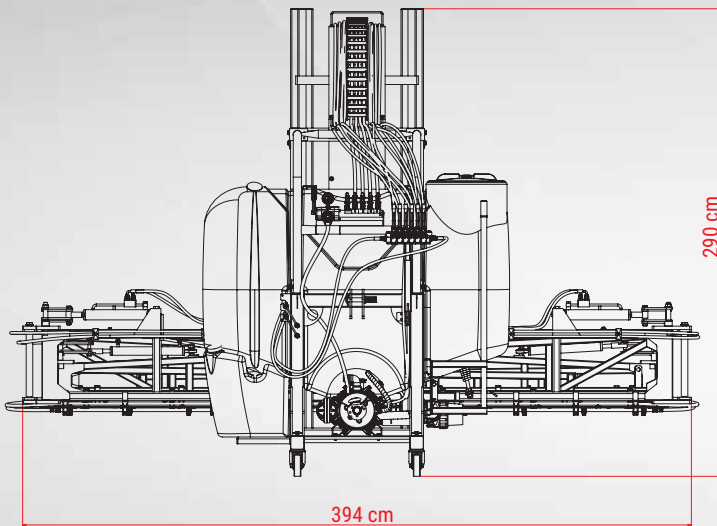

Yükleme Adetleri / Loading Pcs



3



6



3



9

Teknik Özellikler / Technical Specifications

| Pompa Modeli Pump | Piston membranlı Piston diaphragm | Önallar C145 |
|--|--------------------------------------|---|
| Pompa Debisi Pump Flowrate | l/dk l/min | 145 |
| Pompa Basıncı Pump Pressure | Bar | 50 |
| Kontrol Paneli Control Panel | | OPR 40-5 |
| İş Genişliği Working Width | m | 18 |
| Nozul Tipi Nozzle | | Konik hüzmeli piriç Conic beamed and clamped |
| Nozul Sayısı Nr. Of Nozzle | | 37 |
| Nozullar Arası Mesafe The Distance Between Nozzle | cm | 50 |
| İlaçlama Kolu Yüksekliği Ayarı Boom Height Adjustment | | Hidrolik Hydraulic |
| İlaçlama Kolu Katlanması Boom Opening Adjustment | | Manuel Manual |
| Gereken Traktör Gücü Required Power | BG HP | 70-90 |
| Çalışma Devri Speed | dev/dk RPM | 540 |
| Ağırlık Weight | kg | 882 |

Basınçlı suyu süzerek
ilaçlama verimini yükseltir.

*Productivity by filtering
pressured water.*



Makinenin trafikte
farkedilmesini sağlar.

*Enables to be easily
noticeable in the traffic
machine.*



Araziye göre
kolan eğimini
ayarlar.

*Adjusts the
pitch of boom
according to
terrain
condition.*



Kolan hidrolik kumanda
ile kolayca açılıp
kapanmasını sağlar.

*Provides to work easier
the boom by the help of
hydraulic regulator.*



Uzun ömürlü ve
temizlenebilir
nozül homojen
ilaçlama yapar.

*Long-lasting
and cleanable
nozzle provides
homogeneous
disinfection.*



Doldurucu hortumunun
düzenli kalmasını
sağlar.

*Provides regular stay of the
filler hose.*



Depo yıkama sistemi.
Tank cleaning system.



Ana depodan bağımsız
el yıkama tankı temiz
su ihtiyacını karşılar.

*Hand washing tank
apart from main tank
supplies clean water.*



Kumanda ve kol arasındaki
hortumların düzenli
olmasına yarar.

*Cable canals support the
hoses between regulator
and boom against dam.*



Homojen ve hassas
ilaçlama normu sağlar.

*Homogeneous and
sensitive disinfection.*



Hidrolik liflerin uzaktan
kontrolünü sağlar.

*Provides the distant
control of hydraulic lifts.*



Depo Kapağı

Tank Lid



Depoda kalan su miktarını
hassas ölçen şamandıralı
gösterge.

*Sensitive float indicator
which quantifies of residual
water in the tank.*



Temizlenebilir filtre
ilaçlamanın sağlıklı
yapılabilmesini sağlar.

*Cleanable filter enables
homogenous spraying.*



Dökümünden montajına kadar kendi
imalatımız 4 membranlı C145 pompa
sınıfında en iyi performansa sahiptir.

*The best quality 4 membrane C145 pump
which is manufactured by our factory is
the most efficient product of its segment.*



İlaçlama sonrasında depoda
kalan suyun tahliyesini hızlı bir
şekilde gerçekleştirir.

*Fast removing of remained water
on the tank after disinfection.*





ALFA YTP

C145 Pompa Randıman Değerleri / C145 Pump Productivity Rates

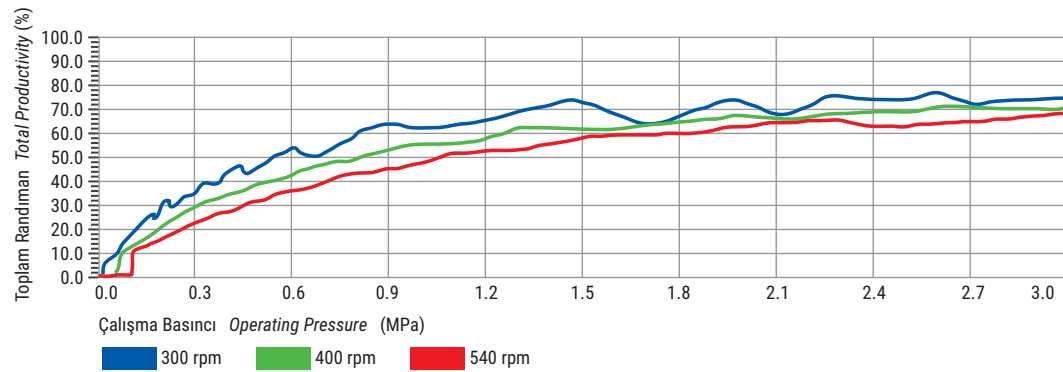

C145 Pompa Verdi Değerleri / C145 Pump Flowrate Rates

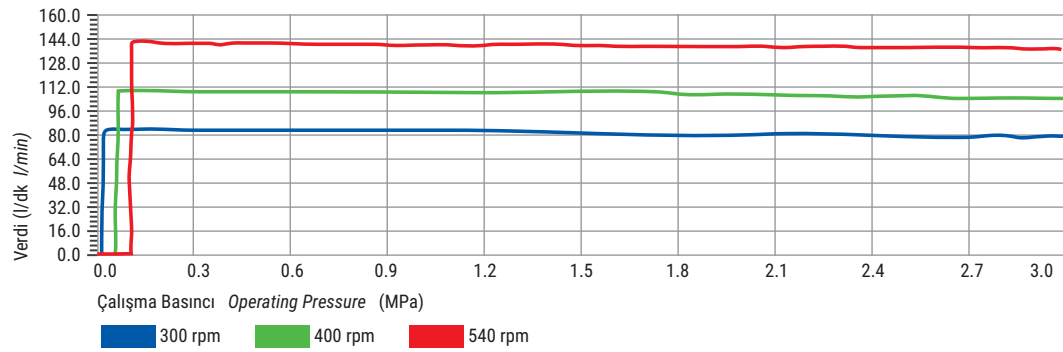

Makine Çalışma Sistemi / Machine Working Principle

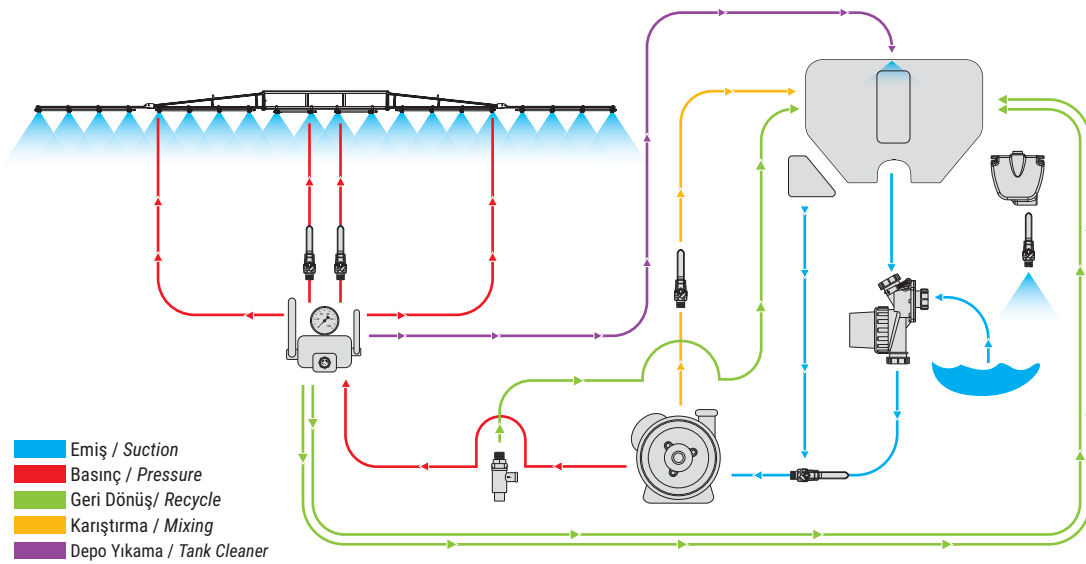

Ayarlanabilir Yükseklik
Adjustable Height

max 125 cm
min 50 cm

16 Metre Kol 16 m Boom / 156 kg / Nozul Dağılımı Nozzle Distribution : 4 5 5 5 5 4

max 125 cm
min 50 cm

18 Metre Kol 18 m Boom / 265 kg / Nozul Dağılımı Nozzle Distribution : 8 7 7 7 8

Ürünlerimizde teknoloji ve çalışma şartlarına bağlı olarak değişiklik yapma hakkımız saklıdır.
Onallar has the right to make changes to manufacturing in the products.

Depo Doldurucusu Test Sonuçları / Test Results Of Filter

Hidrolik tip venturi depo doldurucusunun;
Alfa YTP 800 : 9 dk 2 sn
Alfa YTP 1000 : 11 dk 1 sn'de
3 mpa basınçta 540 devirde doldurduğu tespit edilmiştir.

It is determined that hydraulic type venturi tank filler fills the
Alfa YTP 800 : 9 min. 2 sec.
Alfa YTP 1000 : 11 min. 1 sec.
under operating at 3.0 MPa and 540 rpm cycle.

Bu değerler test ortamında elde edilmiş olup,
şartlara bağlı olarak değişkenlik gösterebilir.

These values are obtained in the test environment
and may vary depending on the conditions.

Hortum Test Sonuçları / Test Results Of Hose

Makinada bulunan hortumların, hortum deney standında çalışma basıncının 3 katı statik basınç altında (9.0 MPa) deforme olmadığı, çap ve form değişikliğine uğramadığı tespit edilmiştir.

Any deformation is not detected on the hoses which are used on the machine, in spite of practicing pressure over three times (9.0 MPa) than operating pressure.

Süzgeçler / Sieves

| Kullanım Yeri Place Of Use | Tipi Type | Malzeme Material Type | Delik Sayısı adet/cm ² Hole Quantity pcs/cm ² | Süzme Oranı % Sieving Rate |
|--|--|-----------------------------------|--|-------------------------------|
| Depo Doldurma Ağız Süzgeci Tank Filler Opening Sieve | Dikdörtgen delikli Rectangular Perforated | Plastik Örgü Plastic Mesh | 180 | 40 |
| Depo Doldurucu Süzgeci Tank Filler Sieve | Kare delikli Square Perforated | Cr+Ni Tel örgü Cr+Ni Wire Mesh | 256 | 33 |
| Depo Çıkış Süzgeci Tank Output Sieve | Kare delikli Square Perforated | Cr+Ni Tel örgü Cr+Ni Wire Mesh | 144 | 30 |
| Malzeme Süzgeci Material Sieve | Kare delikli Square Perforated | Cr+Ni Tel örgü Cr+Ni Wire Mesh | 576 | 56 |

Nozullar Arası Mesafe / Distance Between Nozzles

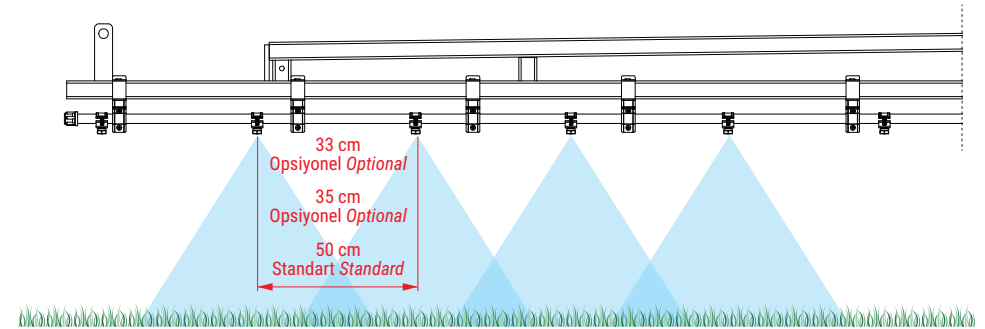

Nozul İlaçlama Şekilleri / Nozzle Spraying Types

Konik Hüzme Nozul
Chonic Brass Nozzle

Plaket delik çapları
Plate hole diameter
0.8 mm
1.0 mm
1.2 mm
1.5 mm
2.0 mm

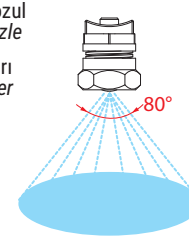



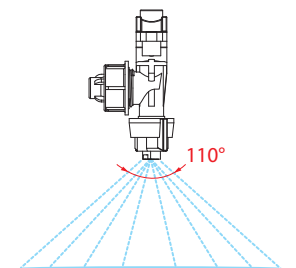

Yelpaze Hüzme Nozul
Curtain Spray Nozzle

Plaket delik çapları
Plate hole diameter
110-01 110-04
110-015 110-05
110-02 110-06
110-025 110-08
110-03



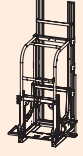
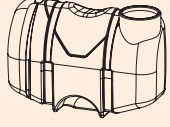
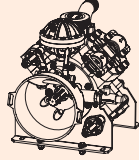
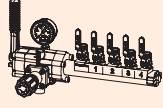

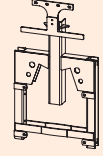
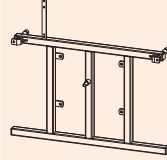

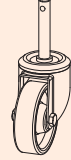
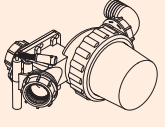
Nozul aralığı ve sayısı isteğe göre değişebilir.
Adjustable nozzle quantity and gap as optional.

STANDART PARÇALAR
STANDARD PARTS

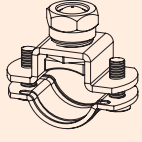
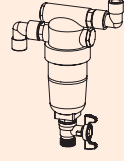
| | | | | | | | | | | |
|---|---|---|--|---|---|---|---|---|---|----------|
|  |  |  |  |  |  |  |  |  |  | |
| Şase | Polietilen depo | C145 Pompa | OPR 40-5 Kumanda | 18 m Kol | Kızak | Beşik | Yükseklik Ayar Lifi | Teker | Filtre | |
| Double Chassis | Polyethylene tank | C145 Pump | OPR 40-5 Regulator | 18 m Boom | Hydraulic Slide | Boom fasten frame | Height Adjustment Lift | Rotary Wheel | 3 Way Filter | |
| Ürün Kodu Product Code | 10300019 | 10003299 (YTP 800) 10003300 (YTP 1000) | 10800004 | 11000004 | 10600013 | 10300006 | 10300011 | 10000154 | 10000290 | 10000355 |

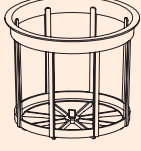
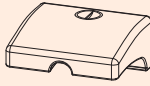
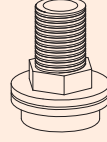

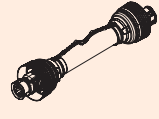

STANDART PARÇALAR
STANDARD PARTS

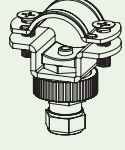
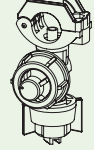
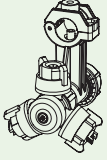
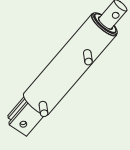
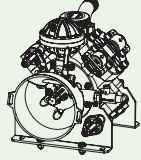
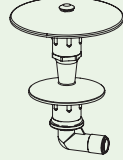
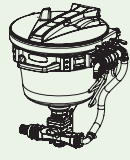
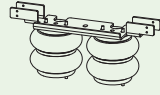
| | | | | | | | | | |
|---|---|---|--|---|---|---|---|---|----------|
|  |  |  |  |  |  |  |  |  | |
| Pirinç Nozul | Basınç Filtresi | Ayaklı Hortum Taşıyıcı | Kapak | Elek | El Yıkama Tank Kiti | Karıştırıcı Kiti | Hızlı Doldurucu Hortum Kiti | Şaft | |
| Brass Nozzle | Pressure Filter | Hose Conveyor with Pad | Cover | Sieve | Hand Washing Tank | Mixer | Fast Filling Hose | Shaft | |
| Ürün Kodu Product Code | 10001355 | 10000103 | 10003754 | 10000385 | 10000407 | 12000052 | 12000017 | 12000051 | 10001214 |



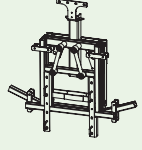

OPSİYONEL PARÇALAR
OPTIONAL PARTS

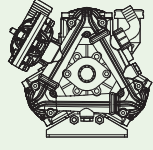
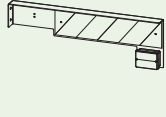
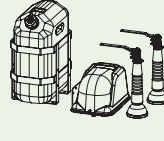
| | | | | | | | | |
|---|---|---|--|---|---|---|---|----------|
|  |  |  |  |  |  |  |  | |
| Tombul Nozul | Yelpaze Hüzmesi Nozul | Üçlü Yelpaze Hüzmesi Nozul | İlaçlama Denge Lifi | APS 145 Pompa | Toz İlaç Karıştırıcı | Mikser | Dikey Süspansiyon | |
| Conic Brass Nozzle | Single Curtain Spray Nozzle | Triple Curtain Spray Nozzle | Spraying Balance Lift | APS 145 Pump | Powder Chemical Mixer | Mixer | Vertical Gusseted Suspension | |
| Ürün Kodu Product Code | 10000177 | 10000405 | 10000406 | 10000824 | 10000326 | 10003326 | 12000053 | 12000054 |

OPSİYONEL PARÇALAR
OPTIONAL PARTS

| | | | | | | | |
|---|---|---|--|---|---|---|----------|
|  |  |  |  |  |  |  | |
| Paralelogram Beşik | Tabanca Kiti | Göstergesi Kiti | Krom Boru | Düşük Basıncılı Pompa | Trafik Uyarı Seti | İz Belirleyici Kiti | |
| Paralelogram fasten frame | Spray Gun | Transparent Level Gauge | Chrome Pipe | Low Pressure Pump | Reverberator + Stop Light | Trace Marker | |
| Ürün Kodu Product Code | 12000055 | 10002745 | 12000056 | 12000057 | 10800007 | 12000060 | 12000061 |

RENK SEÇENEKLERİ
COLOR ALTERNATIVES

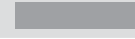
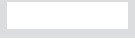
| | | | | | |
|---|---|---|--|---|---|
| 1 | 2 | 3 | | | |
| Şase Chasis | Depo Storage | Şase Chasis | Depo Storage | Şase Chasis | Depo Storage |
|  |  |  |  |  |  |
| Yeşil Green | Turuncu Orange | Siyah Black | Kırmızı Red | Galvaniz Galvanized | Beyaz White |